

# CUBE HOPPER<sup>®</sup> MKII

## Instruction - Service Manual

Model 10-1700-XX

Version 4.0 / Apr 2008

A new design to solve most of your payout problems!

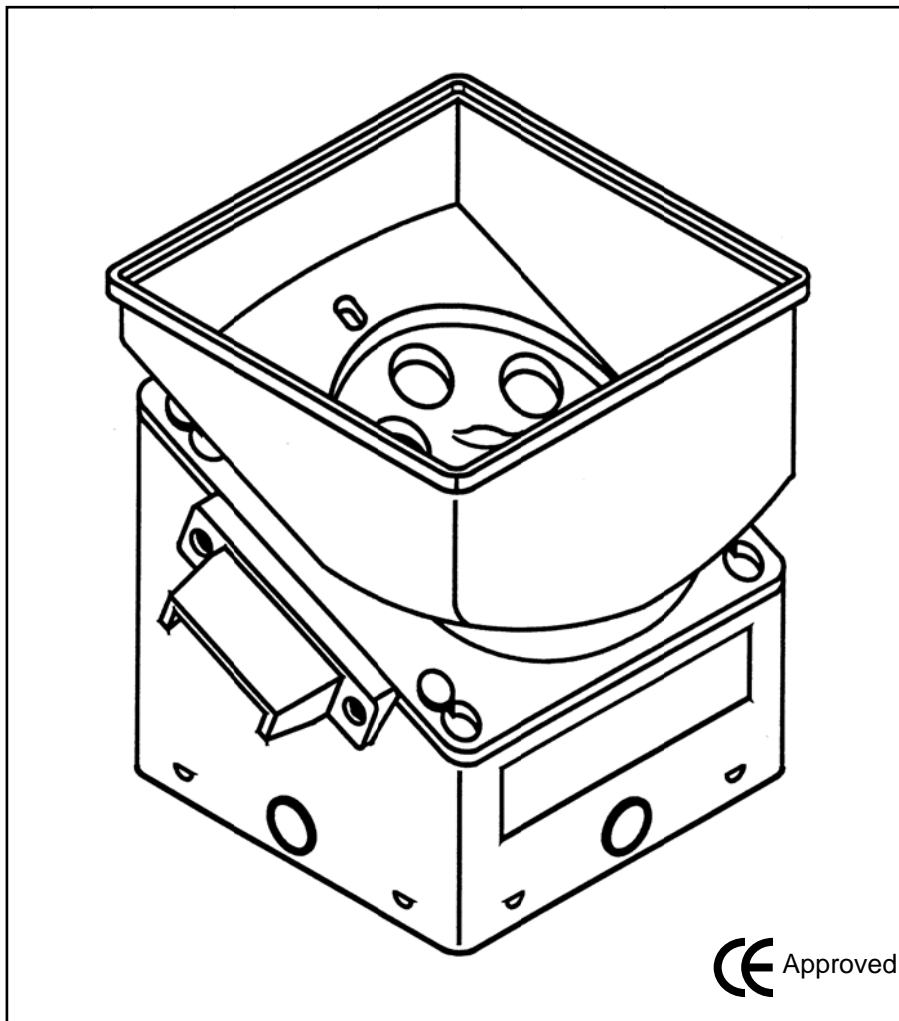

# SUZO

Serving the coin-machine industries since 1955

## TABLE OF CONTENTS

REFERENCE CHART .....	3
INSTRUCTION MANUAL .....	4
<i>Standard hopper for different applications</i> .....	4
<i>Features</i> .....	4
<i>Disassembly</i> .....	4
How to remove the disc .....	4
How to remove the coin insert plate .....	4
How to re-configure the Cube Hopper .....	4
SERVICE MANUAL .....	5
<b>1. Electrical features</b> .....	<b>5</b>
1.1 Connections .....	5
1.2 Motor control .....	5
1.3 Current consumption .....	5
1.4 Power supply requirements .....	5
1.5 Coin counting .....	5
1.6 Continuous monitored optic control .....	5
<b>2. Mechanical features</b> .....	<b>6</b>
2.1 Dimensions & weight .....	6
2.2 Removing the Motor and Gearbox .....	6
2.3 Coin routing .....	6
<b>3. Maintenance</b> .....	<b>7</b>
3.1 Removing and re-installing the hopper .....	7
3.2 Cleaning materials .....	7
3.3 Test equipment .....	7
<b>4. Troubleshooting</b> .....	<b>8</b>
4.1 Motor fails to run .....	8
4.2 Over payout of coins .....	8
4.3 Under payout of coins .....	8
4.4 No payout signal .....	8
<b>5. Optional add-ons</b> .....	<b>9</b>
5.1 Cup extension .....	9
5.2 Driver interface cable .....	9
SCHMATIC DIAGRAM .....	11
EXPLODED VIEW .....	13
CERTIFICATE OF EC COMPLIANCE .....	14
TECHNICAL SPECS .....	15

## REFERENCE CHART

**Model no.10-1700-15**

Diameter 18.00 to 18.99mm. Thickness 1.50 to 2.09mm.  
Disc is marked "2" (Part no. **10-0240-2**).  
Use coin insert plate **11** (Part no. **10-0238-11**).

**Model no.10-1700-20**

Diameter 19.00 to 22.09mm. Thickness 1.50 to 2.09mm.  
Disc is marked "2" (Part no. **10-0240-2**).  
Use coin insert plate **A** (Part no. **10-0238**).

**Model no.10-1700-30**

Diameter 19.00 to 22.09mm. Thickness 2.10 to 3.20mm.  
Disc is marked "3" (Part no. **10-0240-3**).  
Use coin insert plate **A** (Part no. **10-0238**).

**Model no.10-1700-40**

Diameter 22.10 to 23.89mm. Thickness 1.50 to 2.09mm.  
Disc is marked "4" (Part no. **10-0240-4**).  
Use coin insert plate **B1** (Part no. **10-0238-1**).

**Model no.10-1700-41**

Diameter 23.90 to 25.59mm. Thickness 1.50 to 2.09mm.  
Disc is marked "4" (Part no. **10-0240-4**).  
Use coin insert plate **B2** (Part no. **10-0238-2**).

**Model no.10-1700-50**

Diameter 22.10 to 23.89mm. Thickness 2.10 to 3.20mm.  
Disc is marked "5" (Part no. **10-0240-5**).  
Use coin insert plate **B1** (Part no. **10-0238-1**).

**Model no.10-1700-51**

Diameter 23.90 to 25.59mm. Thickness 2.10 to 3.20mm.  
Disc is marked "5" (Part no. **10-0240-5**).  
Use coin insert plate **B2** (Part no. **10-0238-2**).

**Model no.10-1700-83**

Diameter 25.60 to 27.89mm. Thickness 1.50 to 2.09mm.  
Disc is marked "8" (Part no. **10-0240-8**).  
Use coin insert plate **C1** (Part no. **10-0238-3**).

**Model no.10-1700-84**

Diameter 27.90 to 30.09mm. Thickness 1.50 to 2.09mm.  
Disc is marked "8" (Part no. **10-0240-8**).  
Use coin insert plate **C2** (Part no. **10-0238-4**).

**Model no.10-1700-85**

Diameter 30.10 to 31.00mm. Thickness 1.50 to 2.09mm.  
Disc is marked "8" (Part no. **10-0240-8**).  
Use coin insert plate **5** (Part no. **10-0238-5**).

**Model no.10-1700-93**

Diameter 25.60 to 27.89mm. Thickness 2.10 to 3.20mm.  
Disc is marked "9." (Part no. **10-0240-9**).  
Use coin insert plate **C1** (Part no. **10-0238-3**).

**Model no.10-1700-94**

Diameter 27.90 to 30.09mm. Thickness 2.10 to 3.20mm.  
Disc is marked "9." (Part no. **10-0240-9**).  
Use coin insert plate **C2** (Part no. **10-0238-4**).

**Model no.10-1700-95**

Diameter 30.10 to 31.00mm. Thickness 2.10 to 3.20mm.  
Disc is marked "9." (Part no. **10-0240-9**).  
Use coin insert plate **5** (Part no. **10-0238-5**).

### THE "EURO-HOPPERS"

Model no.10-1700-25, "Euro-hopper"

For €0.20 coins.

Disc is marked "99". (Part no. **10-0240-99**).

Use coin insert plate **7** (Part no. **10-0238-7**).

Model no.10-1700-99, "Euro-hopper"

For €0.50, €1.00 and €2.00 coins.

Disc is marked "99". (Part no. **10-0240-99**).

Use coin insert plate **B1** (Part no. **10-0238-1**).

### Payout discs

Mark on disc		Diameter*	Thickness*	Part no.
New	Old			
2	A	18.00 - 22.09	1.50 - 2.09	10-0240-2
22		18.00 - 22.09	1.30 - 1.45	10-0240-22
3	AA	18.00 - 22.09	2.10 - 3.20	10-0240-3
4	B	22.10 - 25.59	1.50 - 2.09	10-0240-4
44		22.10 - 25.59	1.30 - 1.45	10-0240-44
5	BB	22.10 - 25.59	2.10 - 3.20	10-0240-5
	6 / C	25.60 - 30.09	1.50 - 2.09	10-0240-6
	7 / CC	25.60 - 30.09	2.10 - 3.20	10-0240-7
8		25.60 - 31.00	1.50 - 2.09	10-0240-8
9		25.60 - 31.00	2.10 - 3.20	10-0240-9
99		€0.20 - €0.50 - €1.= - €2.=		10-0240-99

### Coin insert plates

Mark on plate	Diameter*	Part no.
11	18.00 - 18.99	10-0238-11
A	19.00 - 22.09	10-0238
B1	22.10 - 23.89	10-0238-1
B2	23.90 - 25.59	10-0238-2
C1	25.60 - 27.89	10-0238-3
C2	27.90 - 30.09	10-0238-4
5	30.10 - 31.00	10-0238-5
7	for €0.20	10-0238-7

\*all sizes are in millimetres (mm)

### PLEASE NOTE:

Changes have been made to the previously used configuration of the Cube Hopper.

- Payout disc 10-0240-6: replaced by 10-0240-8.
- Payout disc 10-0240-7: replaced by 10-0240-9.
- Hopper 10-1700-60: replaced by 10-1700-83.
- Hopper 10-1700-61: replaced by 10-1700-84.
- Hopper 10-1700-70: replaced by 10-1700-93.
- Hopper 10-1700-71: replaced by 10-1700-94.

### Which hopper to use for which Euro-coin:

€0.01	Not available	€0.20	10-1700-25
€0.02	10-1700-15	€0.50	10-1700-99
€0.05	10-1700-20	€1.00	10-1700-99
€0.10	10-1700-20	€2.00	10-1700-99

Congratulations on your purchase of this **CUBE HOPPER MKII** and thank you for having confidence in our **STC** quality products

## Instruction Manual

### **Standard hopper for different applications**

The CUBE HOPPER is a single coin payout system made universal by using the relevant payout disc and coin insert plate (see Reference Chart).

It can be used with all round coins with a diameter between 18.00 and 31.00mm and a thickness ranging from 1.30 to 3.20mm.

### **Features**

The hopper is square and easy to mount by means of a standard mounting-bracket (included).

By using a unique "sun and planet" gearbox system this hopper offers the possibility to contain and count up to 1,000 coins of €0.50 (if fitted with two cup-extensions).

The hopper is protected by an auto-reverse anti-jam system and has an indirect optical readout.

A low level sensing detection is integrated into the coin cup and can be connected to pin 1 and 2 of the connector.

When using the correct pin on the connector, the hopper operates on a low safe voltage (12VDC or 24VDC).

### **PLEASE NOTE:**

This unit was not designed to be used solely as a coin counter. Before starting a payout, there should already be coins present in the coin cup. These coins should be at rest before payout occurs. The motor should only be active while a payout is in progress.

### **Disassembly**

#### **How to remove the disc**

- a) Slide the red button on the back to "down" position.
- b) Remove the coin cup by sliding it upwards and lift the cup from the platform.
- c) You are now able to remove the disc from the platform.

#### **How to remove the coin insert plate**

- a) Remove the cup and disc from the platform as described above.
- b) Remove the outlet bridge by pulling it up firmly.
- c) Gently lift up the coin insert plate using a small screwdriver.

#### **How to re-configure the Cube Hopper**

- a) Remove the coin cup.
- b) Remove the disc and/or coin insert plate (if necessary) and replace them with the ones necessary to achieve the desired configuration.  
Before placing the new disc onto the platform:
  - I) Please check that the correct coin insert plate is mounted on the platform under the bridge.  
(See Reference Chart)
  - II) Don't forget to put the black Teflon bearing in the centre of the platform. Make sure that the metal ring in the disc is present as well.
- c) Bring the coin cup onto the platform and slide the red button to the up position to lock it in place.

NOTE: Please look up the correct configuration for your hopper in the Reference Chart.

# Service Manual

## 1. Electrical features

### 1.1 Connections

Pin 1	low level
Pin 2	low level (common).
Pin 3	pin cut out, optional lock.
Pin 4	continuous monitored optic control, power +12 / +24VDC.
Pin 5	Reserved
Pin 6	optic-sensor signal: coin out
Pin 7	+24VDC supply and motor control.
Pin 8	+12VDC supply and motor control.
Pin 9	Ground common supply.

You can use a 9-pin Molex connector (Suzo Part no. 22-01-2095) and crimp terminals (Suzo Part no. 08-50-0032) or equivalent with a pitch of 0.1" (2.54mm).

**Be careful with the pin numbering of the connector, because not all manufacturers start numbering from the same pin.**

Furthermore, all assemblies are connected to the main PCB with JST connectors.

### 1.2 Motor control

Connecting and interrupting the +12 or +24VDC supply controls the motor.

The motor is automatically stopped when the power-supply is switched off.

Motor duty cycle is 2:1.

An electronic overload detection system protects the motor and in case of a coin jam it will temporarily turn the hopper disc several times in the opposite direction until the jam is solved if not the motor switches itself off.

### 1.3 Current consumption

With maximum coin load: 850mA average.

Current is zero whilst stopped (hopper disconnected).

Motor start-up and reversing surge: 2A falling to approx. 850mA (hopper full) or 400mA (hopper empty) after 200ms.

### 1.4 Power supply requirements

- 12VDC and 24VDC nominal ( $\pm 10\%$ )
- maximum ripple voltage  $\pm 2.4V$
- absolute maximum voltage: 26.4VDC
- minimal voltage when using 24VDC connection: 18VDC
- minimal voltage when using 12VDC connection: 10.8VDC
- switch / reverse current: 2A

### 1.5 Coin counting

Coin counting speed is 6 to 7 coins per second. All paid out coins pass by the optical sensor indirectly.

The coin exit output changes from high impedance to low impedance status.

This output stays high as long as the hopper is in the "Off" status (power disconnected).

When a coin appears at the counter pawl under the exit bridge the PCB controls the coin verification and releases a logic signal. The opto-coupler and the counter pawl detect paid-out coins.

Payout signal: open collector NPN - active low, maximum sink of 25mA at 35Volt maximum.

Minimum time obstructs optics 30ms - minimum.

Time between coins:  $\pm 100ms$ .

### 1.6 Continuous monitored optic control

It is possible to continuous monitored optic sensor for overpay.

To do this you have to power pin 4 with +12/+24VDC.

This extra security is possible from PCB part number 10-0210-1

## 2. Mechanical features

### 2.1 Dimensions & Weight

Dimensions:

D: 122mm

W: 122mm

H: 153mm

Weight:

780 grams

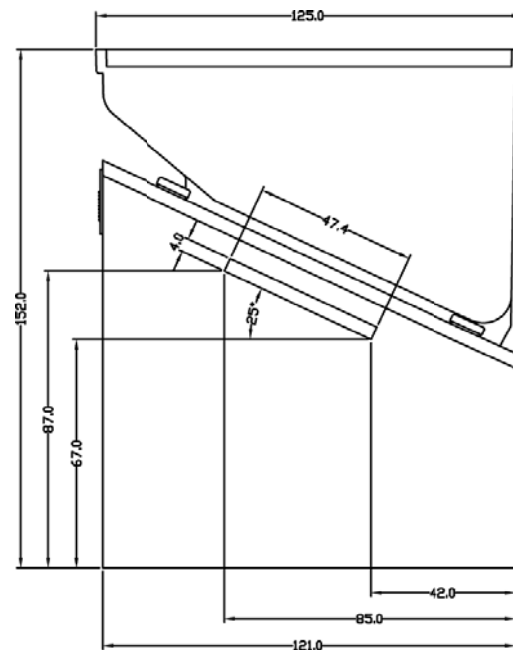

PAY-OUT SIDE

### 2.2 Removing the Motor and Gearbox

The motor is controlled by the PCB and operates the disc by means of gears and shafts.

The gearbox is constructed according to the sun and planet system.

The motor can easily be exchanged by first unplugging the connector from the PCB and then dismantling the motor holder which is connected to the gear box by means of a bayonet catch.

Press down the engraved slide on the motor housing and turn the motor housing in an anti-clockwise direction to take it off.

Now take a new motor and refit into the motor holder.

The gearbox can also be removed completely by unscrewing the three screws, which attach the gearbox to the platform and removing the rolling-pin on top of the motor shaft.

The Counter Pawl fits an Opto output detector with a transmitter inside the Hopper. The Counter Pawl makes sure that the coin always leaves the Hopper and the construction is done in such a way that once the coin leaves the disc it can never return to the Hopper.

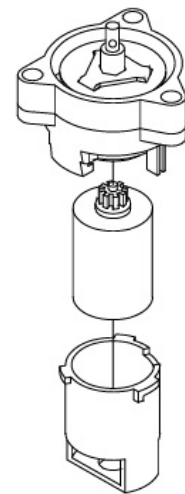

### 2.3 Coin routing

The coins enter the hopper via the top of the Coin Cup and are ejected sideways via the Coin Exit.

### 3. Maintenance

Important: shut-off power from the host machine before starting any cleaning activities.

#### 3.1 Removing and re-installing the hopper

The hopper can easily be removed by pressing on the red release button on the mounting plate and then removing the connector.

Re-installing the hopper:

First plug the connector into the Hopper at the reverse side and slide it into the two red hooks on the mounting bracket, then press the red button with lever slightly backwards and push the hopper onto the bracket.

#### 3.2 Cleaning and Materials

All reachable places where the coins pass through the hopper should be cleaned at least every 6 months or after counting 500,000 coins (whichever situation occurs first) with a moist cloth with dry silicon spray (Part No. 20-0124-1).

In particular the opto coupler needs to be kept clean.

Dirt could obstruct or disrupt the optic signal, resulting in unreliable coin counting.



#### 3.3 Test equipment

General testing equipment (like multi-meter) is all you need on the road to enable you to make a diagnosis of the problem with the CUBE HOPPER.

For use in the workshop, we sell special test equipment (Part no. 10-0155).



## **4. Troubleshooting**

### **4.1 Coins fail to unjam**

- a. Are you using the correct coin insert plate? (see Reference Chart)
- b. Are you using the right disc? (see Reference Chart)
- c. Be sure Opto Coupler is clear!
- d. Are there bad or incorrect coins in the hopper?

### **4.2 Motor fails to run.**

- a. Check the hopper fuse of the host machine.
- b. Protection device tripped - wait for 30 seconds with the power switched off.

### **4.3 Over payout of coins.**

- a. Check the opto coupler for accumulated dirt or dust.
- b. Check exit monitoring by the host machine.
- c. Check if the hopper's power is not disconnected too slowly. Power should be disconnected directly after the registration of the ejection of the last coin of the payout.
- d. Are you using the correct coin insert plate? (see Reference Chart)

### **4.4 Under payout of coins.**

- a. Make sure the hopper has sufficient coins.
- b. Incorrect registration by the host machine.
- c. Incorrect exit output, debouncing by the host machine.
- d. Bad contact with the hopper.

### **4.5 No payout signal**

- a. Please check coin insert plate.(for reference, see page 2).



## 5. Optional add-ons

### 5.1 Cup extension (Part No. 10-0200)

A 65mm high extension together with standard coin-cup increases the capacity of the cup from 400 to 700 coins of €0.50 (24.25mm in diameter, 2.4mm thick). It can be used with all coins with diameters up to 31mm.

A second extension is possible for coins with a maximum diameter of 25.6mm. This increases the capacity to 1,000 coins of €0.50.

Hopper dimensions - with one extension:

D: 122mm    W: 122mm    H: 218mm

Hopper dimensions - with two extensions:

D: 122mm    W: 122mm    H: 284mm

Weight

860 grams

940 grams

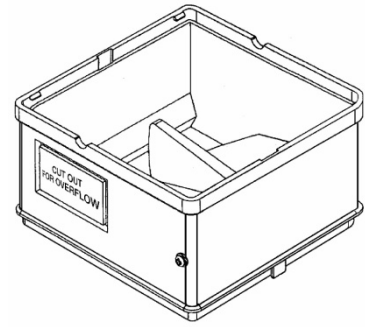

### 5.2 Driver interface Cable (Part No. 10-0150-1)

The uses for this interface are two-fold.

If the switching transistor in the host machine is not powerful enough to drive the CUBEHOPPER, this interface will solve that problem.

It also solves the problem of coins remaining in the coin exit.

This sometimes happens if the STOP-command is received too early.

By checking the coin-out sensor, the interface will turn the motor until the coin blocking the optic sensor is ejected.



### 5.3 Cube Hopper spillage cover (Part No. 10-0005)

Designed to prevent coin spillage.

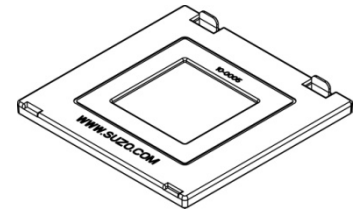

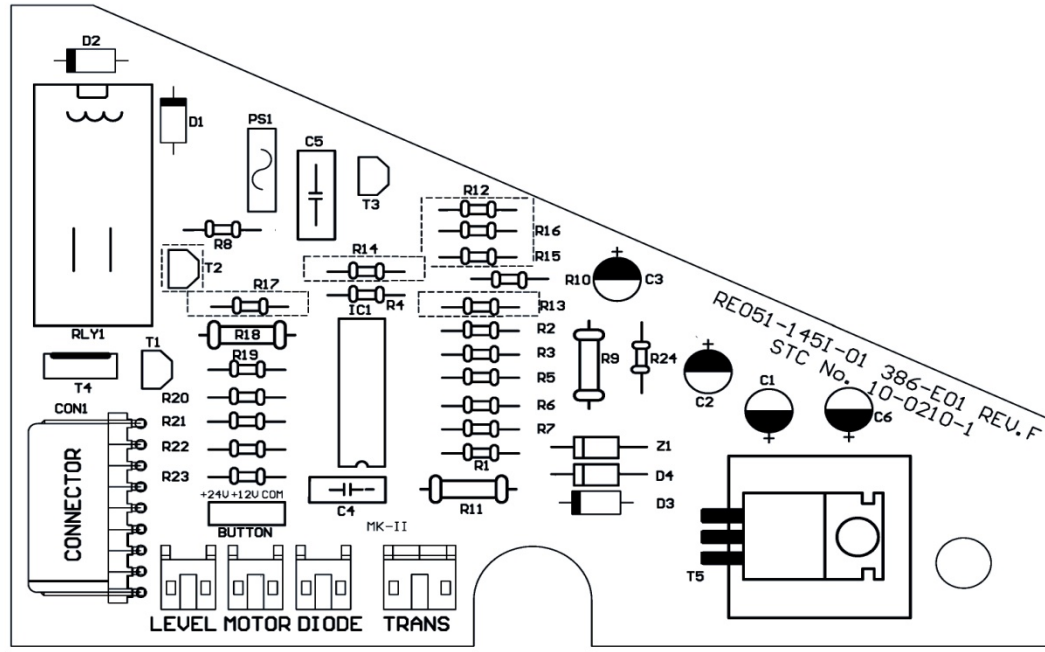

MODIF:	DATE:	CHECK:	NOTE:	
MODIF:	DATE:	CHECK:		
MODIF:	DATE:	CHECK:		
DRAW: MPM	DATE: 11-10-2007	CHECK:	MATERIAL:	
FILE: 10-0210-1.DWG	SCALE:	A 3		MEASUR: MM
<b>SUZO</b>			DESCRIPTION:	TOLER: ±0.1
			COMPONENT LAYOUT MAIN PCB CUBEHOPPER	DRW.NO:
			PART NO:	00
			10-0210-1	

LAYOUT 10-0210-1

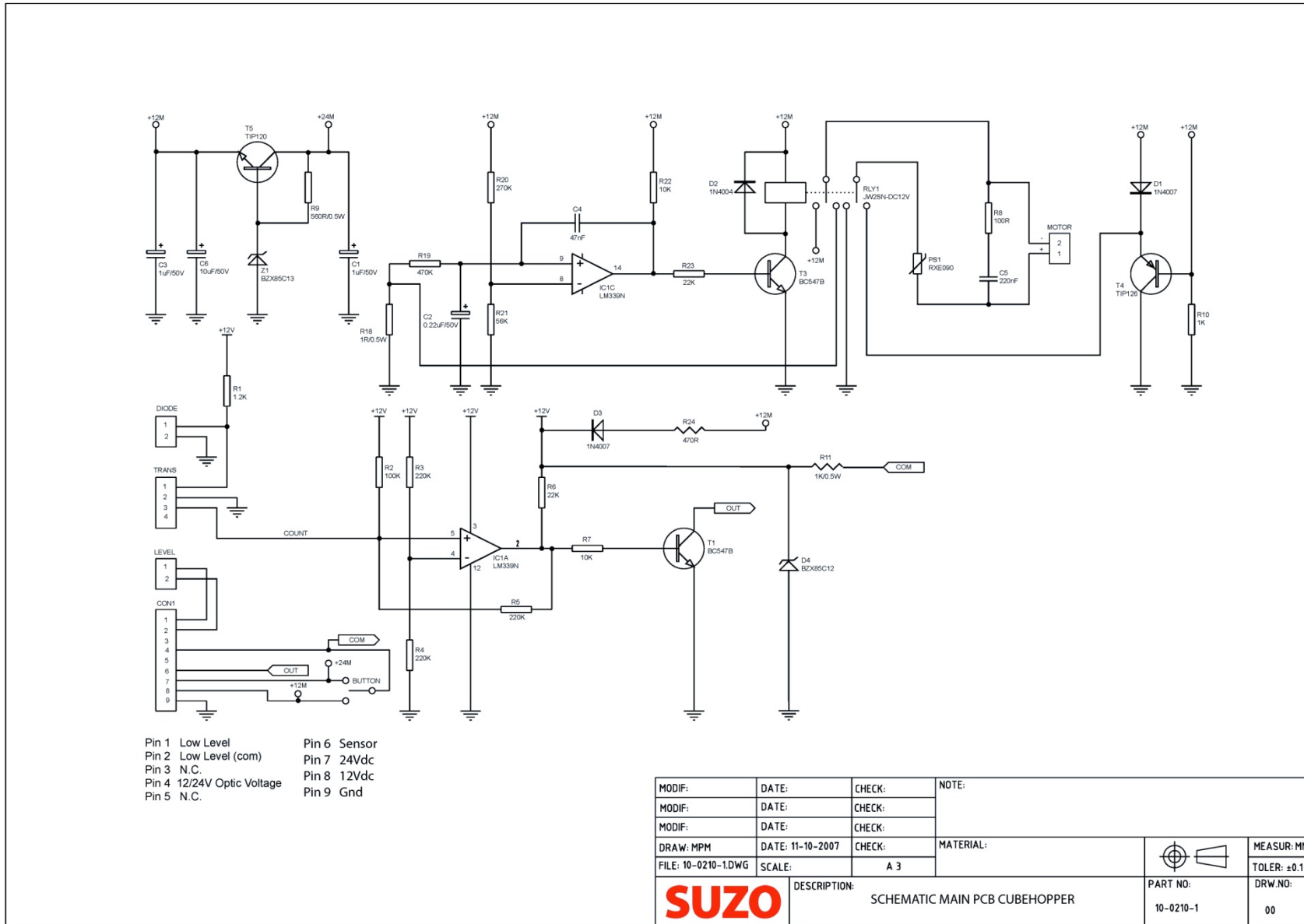

SCHEMATIC DIAGRAM 10-0210-1

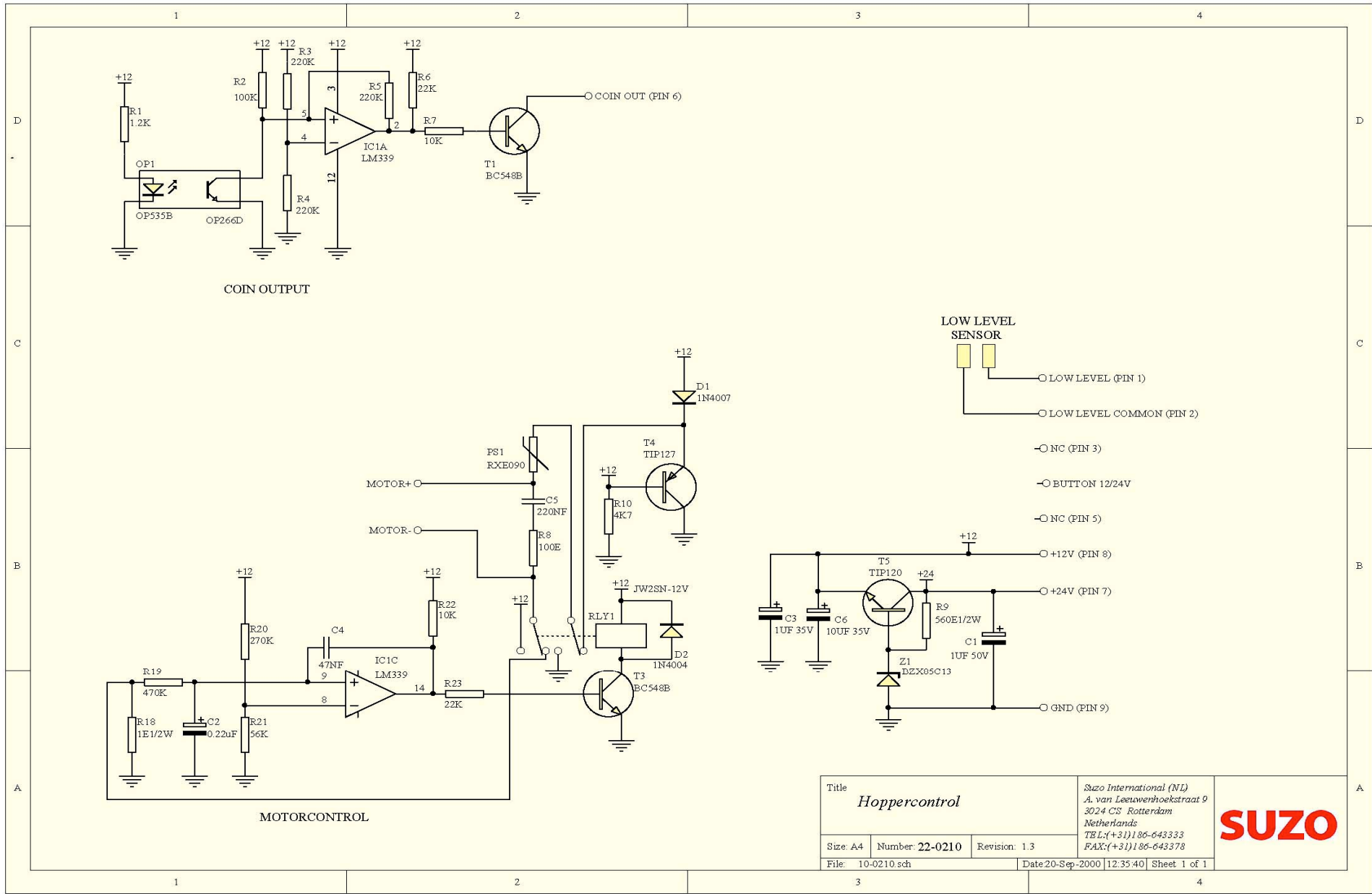

SCHEMATIC DIAGRAM 10-0210

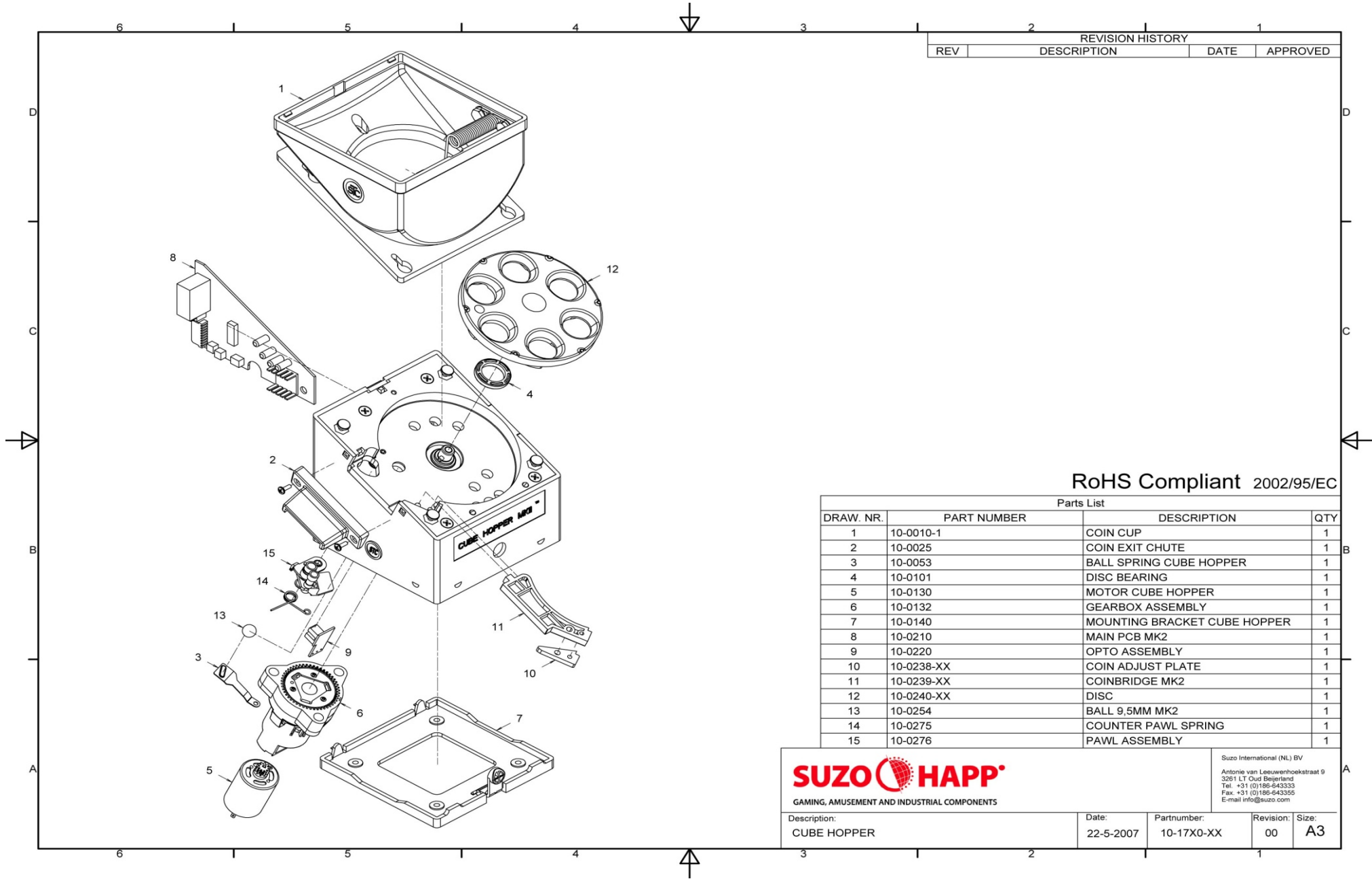

REVISION HISTORY			
REV	DESCRIPTION	DATE	APPROVED

RoHS Compliant 2002/95/EC

Parts List			
DRAW. NR.	PART NUMBER	DESCRIPTION	QTY
1	10-0010-1	COIN CUP	1
2	10-0025	COIN EXIT CHUTE	1
3	10-0053	BALL SPRING CUBE HOPPER	1
4	10-0101	DISC BEARING	1
5	10-0130	MOTOR CUBE HOPPER	1
6	10-0132	GEARBOX ASSEMBLY	1
7	10-0140	MOUNTING BRACKET CUBE HOPPER	1
8	10-0210	MAIN PCB MK2	1
9	10-0220	OPTO ASSEMBLY	1
10	10-0238-XX	COIN ADJUST PLATE	1
11	10-0239-XX	COINBRIDGE MK2	1
12	10-0240-XX	DISC	1
13	10-0254	BALL 9,5MM MK2	1
14	10-0275	COUNTER PAWL SPRING	1
15	10-0276	PAWL ASSEMBLY	1



**SUZO HAPP**  
GAMING, AMUSEMENT AND INDUSTRIAL COMPONENTS

Suzo International (NL) BV  
 Antonie van Leeuwenhoekstraat 9  
 3261 LT Oud Beijerland  
 Tel: +31 (0)186-643333  
 Fax: +31 (0)186-643355  
 E-mail: info@suzo.com

Description: CUBE HOPPER	Date: 22-5-2007	Partnumber: 10-17X0-XX	Revision: 00	Size: A3
-----------------------------	--------------------	---------------------------	-----------------	-------------

Certificate number: 99C00323CRT0

*Dijkstra Advies, Research & EMC Consultancy B.V.*

Competent Body

# Certificate of Compliance

EMC directive - 89/336/EG

This certifies that :

Product name: CUBE Hopper MKII

Model number: 10-1700-61 (Electronic: 10-0110)

Serial number: 980300050

(product identification)

imported or manufactured by:

Suzo International B.V.

Antonie van Leeuwenhoekstraat 9

3261 LT OUD BEIJERLAND

The Netherlands

has been tested on:

June 1999

and has been found in compliance with:

EN 55014 (1993)

EN 55104 (1995)

*D.A.R.E.II* Consultancy

D. van der Vlugt

Managing Consultant

signature

Woerden, June 10, 1999

*Dijkstra Advies, Research & EMC Consultancy B.V. - Vijzelmolenlaan 7 - 3447 GX WOERDEN - The Netherlands*

Tel.: +31 (0)348 430979 - Fax: +31 (0)348 430645 - KvK Utrecht 30138675 - Rabobank Woerden 15.83.13.704

VAT number: NL8056.13.468.B01 - Internet: [www.dare.nl](http://www.dare.nl) - Email: [info@dare.nl](mailto:info@dare.nl)

## TECHNICAL SPECIFICATIONS

<b>Nominal Operating Voltage</b>	12VDC $\pm$ 10% or 24VDC -25% +10%
<b>Minimal Operating Voltage</b>	<b>Pin 8</b> : 10.8VDC / <b>Pin 7</b> : 18V DC
<b>Storage temperature</b>	- 20°C to + 70°C.
<b>Operating temperature</b>	- 0°C to + 50°C.
<b>Humidity</b>	Min. 20% - Max. 75%
<b>Motor Duty Cycle</b>	2:1
<b>Payout speed</b>	6 to 7 coins per second
<b>Payout position</b>	4 sides
<b>Max. current not loaded</b>	400mA
<b>Max. current loaded</b>	850mA
<b>Max. current</b>	2A (when jamming)
<b>Connector</b>	9-way connector, Part No. 22-01-2095 + Pins, Part No. 08-50-0032
<b>Payout signal</b>	Open collector-active low 25mA-35V
<b>Coin Diameter size</b>	18mm - 31mm
<b>Coin Thickness size</b>	1.5mm - 3.2mm
<b>Min. time between coins</b>	100ms
<b>Min. time obstructs optics</b>	30ms
<b>Maintainable life</b>	>3 millions
<b>Maintainable disk</b>	750.000 – 1.000.000

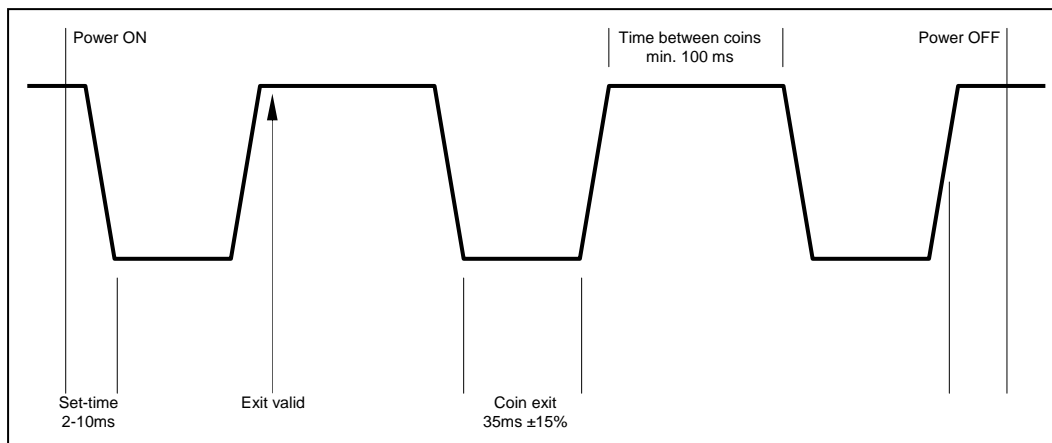

Design and specifications are subject to change without notice.

Wijzigingen in ontwerp en technische gegevens voorbehouden, zonder kennisgeving.

La conception et les spécifications sont modifiables sans préavis.

El diseño y especificaciones están sujetos a cambios sin previo aviso.

This manual is intended only to assist the reader in the use of this product and therefore Suzo International shall not be held liable for any loss or damage whatsoever arising from the use of any information or particulars in, or any omission from this manual or any incorrect use of the product.

### **WARNING!**

**Failure to observe the interface requirements specified in this technical manual may result in miscounts, damage to the electronics and the motor of the hopper or create unacceptable voltage drops, affecting other units depending on the same power supply.**

# SUZO

SUZO INTERNATIONAL (NL)

Antonie van Leeuwenhoekstraat 9

3261 LT Oud Beijerland The Netherlands

TEL: +31 (0)186 643333 \* FAX: +31 (0)186 643322

E-MAIL: [info@suzo.com](mailto:info@suzo.com)

WEB: [www.suzo.com](http://www.suzo.com)